

# TITAN

## 31 SERIES

WEIGHT-SENSING FORK COVERS

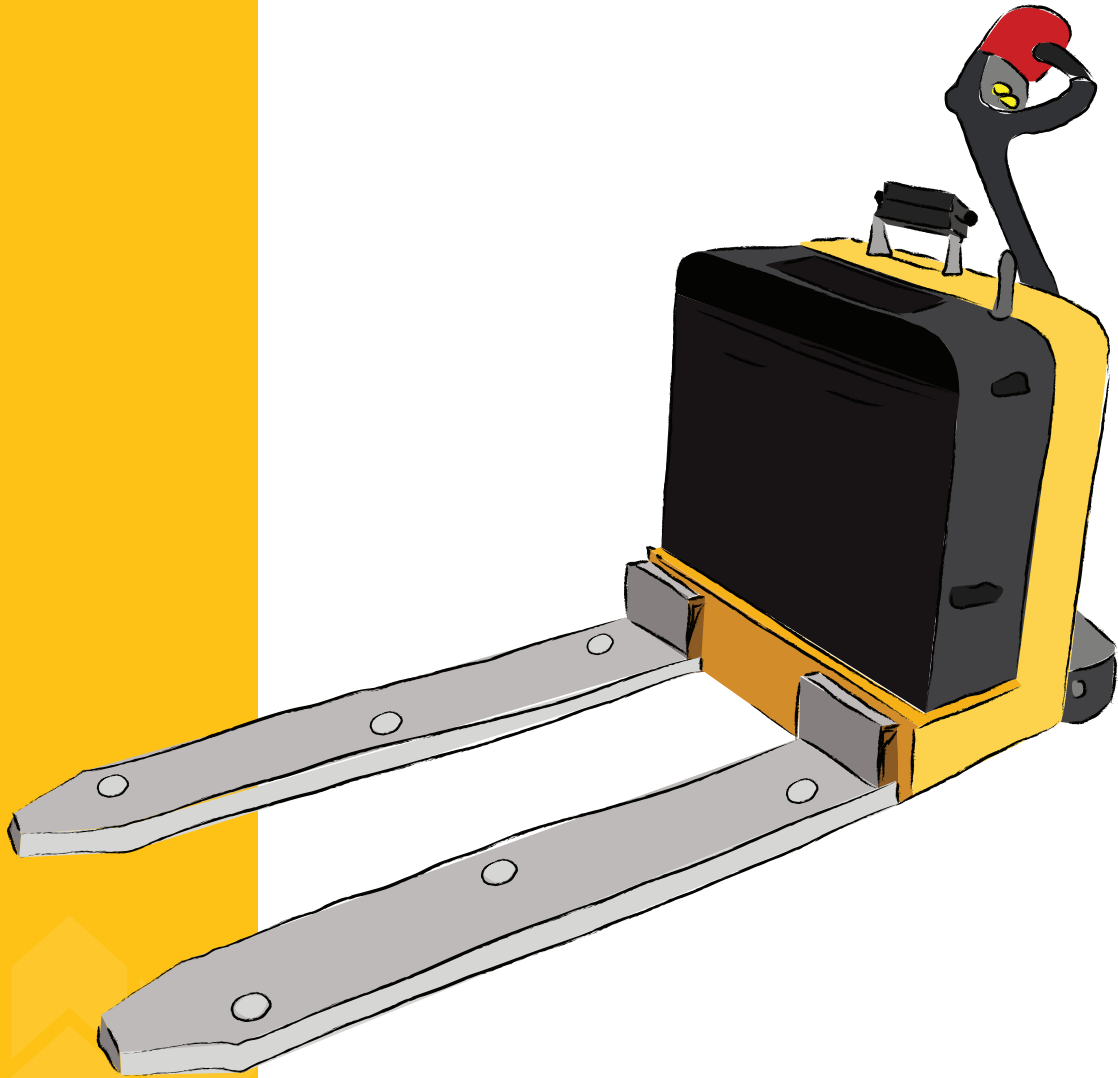

## EWS31

### ELECTRIC WALKIE SCALE



The Titan 31 Series of scales feature our weight-sensing fork cover design. The fork covers simply slide onto the existing forks turning your electric walkie into a mobile-weighing machine! With no modification to existing equipment, our Titan 31 Series scales can be easily removed and re-installed or transferred between trucks.

The system comprises of two main components:

- 1 one set of weight-sensing fork covers - the fork covers are made of plate steel and embedded with metal foil strain gauges
- 2 a robust stainless steel digital indicator with overload alarm

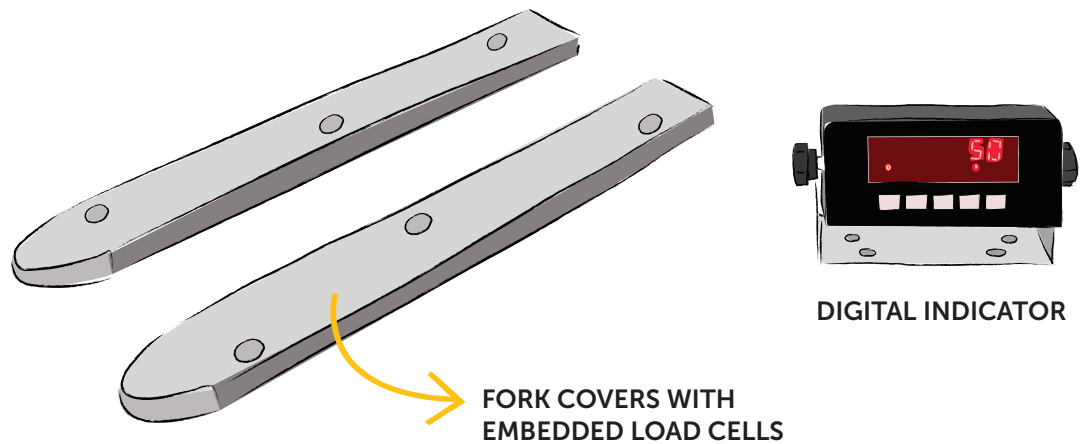

## Options:



## Features & Benefits:

- ▶ Patented, weight-sensing fork cover design
- ▶ Highly accurate; 99% or better +/- 15 lbs.
- ▶ Rugged, heavy duty construction and weatherproofing suitable for outdoor applications
- ▶ Perfect for attaching to leased equipment
- ▶ Does not down rate the truck capacity
- ▶ Light-weight system; reduced shipping cost
- ▶ High overload capacity
- ▶ Large bright LED weigh display
- ▶ Adaptable to most data equipment systems
- ▶ Minimal truck alternation maintains original manufacturer warranty
- ▶ Power derived from truck's battery
- ▶ Maintains original fork profile; adds just fractions to existing forks: 0.625" thickness, 0.5" length, 0.875" width, 0.35" lowered height
- ▶ Made in Canada

### Follow our quick, self-install system

- 1** Secure the fork covers onto the truck's forks
- 2** Mount indicator in desired location
- 3** Connect the indicator to the covers and the truck's battery
- 4** Turn indicator on

**The system comes pre-calibrated so it's ready to use!**

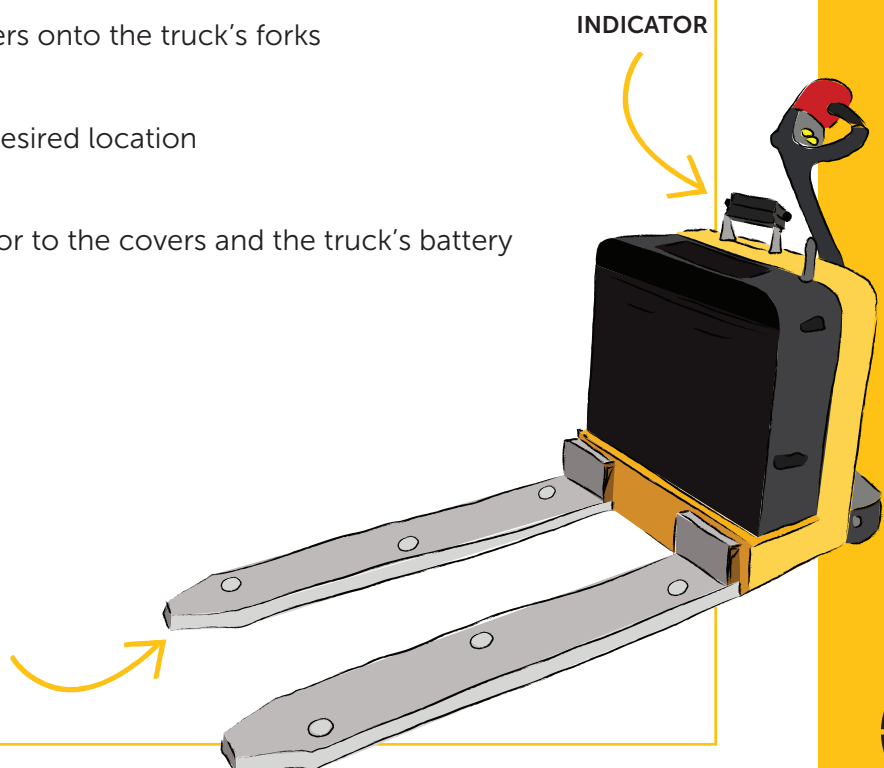



**AFFORDABLE  
MOBILE WEIGHING  
SOLUTIONS**

55 Fleming Drive, Unit 4  
Cambridge, ON  
N1T 2A9  
[weighpoint.com](http://weighpoint.com)

[info@weighpoint.com](mailto:info@weighpoint.com)  
519-622-7922  
800-268-7400